

Gas Gauge IC for Power-Assist Applications

Features

- Accurate measurement of available charge in rechargeable batteries
- Designed for electric assist bicycles and other applications
- Measures a wide dynamic current range
- Supports NiCd, NiMH or lead acid
- Designed for battery pack integration
 - 120µA typical standby current (self-discharge estimation mode)
 - Small size enables implementations in as little as ½ square inch of PCB
- Direct drive of LEDs for capacity display
- Automatic charge and self-discharge compensation using internal temperature sensor
- Simple single-wire serial communications port for subassembly testing
- 16-pin narrow SOIC

General Description

The bq2013H Gas Gauge IC is intended for battery-pack installation to maintain an accurate record of a battery's available charge. The IC monitors a voltage drop across a sense resistor connected in series between the negative battery terminal and ground to determine charge and discharge activity of the battery. The bq2013H is designed for high capacity battery packs used in high-discharge rate systems.

Battery self-discharge is estimated based on an internal timer and temperature sensor. Compensations for battery temperature, rate of charge, and self-discharge are applied to the charge counter to provide available capacity information across a wide range of operating conditions. Initial battery capacity, self-discharge rate, display mode, and charge compensation are set using the PROG₁₋₆ pins. Actual battery capacity is automatically "learned" in the course of a discharge cycle from full to empty.

Nominal available charge may be directly indicated using a five-segment LED display. These segments are used to graphically indicate nominal available charge.

The bq2013H supports a simple single-line bi-directional serial link to an external processor (common ground). The bq2013H outputs battery information in response to external commands over the serial link. To support battery pack testing, the outputs may also be controlled by command. The external processor may also overwrite some of the bq2013H gas gauge data registers.

The bq2013H may operate directly from four nickel cells or three lead acid. With the REF output and an external transistor, a simple, inexpensive regulator can be built to provide V_{CC} from a greater number of cells.

Internal registers include available charge, temperature, capacity, battery ID, and battery status.

Pin Connections

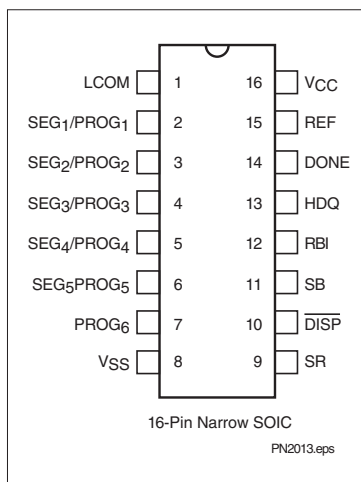

Pin Names

| | | | |
|-------------------------------------|---------------------------------|--------------------------|------------------------------------|
| LCOM | LED common output | REF | Voltage reference output |
| SEG ₁ /PROG ₁ | LED segment 1/ Program 1 input | DONE | Fast charge complete input |
| SEG ₂ /PROG ₂ | LED segment 2 / Program 2 input | HDQ | Serial communications input/output |
| SEG ₃ /PROG ₃ | LED segment 3/ Program 3 input | RBI | Register backup input |
| SEG ₄ /PROG ₄ | LED segment 4/ Program 4 input | SB | Battery sense input |
| SEG ₅ /PROG ₅ | LED segment 5/ Program 5 input | $\overline{\text{DISP}}$ | Display control input |
| PROG ₆ | Program 6 input | SR | Sense resistor input |
| | | V _{CC} | Supply voltage |

bq2013H

Pin Descriptions

LCOM **LED common**

This open-drain output switches V_{CC} to source current for the LEDs. The switch is off during initialization to allow reading of $PROG_{1-5}$ pull-up or pull-down program resistors. LCOM is also high impedance when the display is off.

SEG₁–SEG₅ **LED display segment outputs (dual function with PROG₁–PROG₅)**

Each output may activate an LED to sink the current sourced from LCOM.

PROG₁–PROG₆ **Programmed full count selection inputs (dual function with SEG₁ - SEG₅)**

These three-level input pins define the programmed full-count (PFC), display mode, self-discharge rate, offset compensation, overload threshold, and charge compensation.

SR **Sense resistor input**

The voltage drop (V_{SR}) across the sense resistor R_S is monitored and integrated over time to interpret charge and discharge activity. The SR input (see Figure 1) is connected between the negative terminal of the battery and ground. $V_{SR} > V_{SS}$ indicates charge, and $V_{SR} < V_{SS}$ indicates discharge. The effective voltage drop, V_{SRO} , as seen by the bq2013H is $V_{SR} + V_{OS}$.

DONE **Charge complete input**

This input/output is used to communicate the status of an external charge controller to the bq2013H.

\overline{DISP}

Display control input

\overline{DISP} pulled high disables the display. \overline{DISP} floating allows the LED display to be active during certain charge and discharge conditions. Transitioning \overline{DISP} low activates the display.

SB

Secondary battery input

This input monitors the scaled battery voltage through a high-impedance resistive divider network for the end-of-discharge voltage (EDV) thresholds.

RBI

Register backup input

This input is used to provide backup potential to the bq2013H registers during periods when $V_{CC} < 3V$. A storage capacitor can be connected to RBI.

HDQ

Serial I/O pin

This is an open-drain bidirectional communications port.

REF

Voltage reference output for regulator

REF provides a voltage reference output for an optional micro-regulator.

V_{CC}

Supply voltage input

V_{SS}

Ground

Functional Description

General Operation

The bq2013H determines battery capacity by monitoring the amount of charge input to or removed from a rechargeable battery. The bq2013H measures discharge and charge currents, estimates self-discharge, monitors the battery for low-battery voltage thresholds, and compensates for temperature and charge rates. The charge measurement is made by monitoring the voltage across a small-value series sense resistor between the battery's negative terminal and ground. The available battery charge is determined by monitoring this voltage over time and correcting the measurement for the environmental and operating conditions.

Figure 1 shows a typical battery pack application of the bq2013H using the LED display. The bq2013H can be configured to display capacity in either a relative or an absolute display mode. The relative display mode uses the last measured discharge capacity of the battery as the battery "full" reference. The absolute display mode uses the programmed full count (PFC) as the full reference, forcing each segment of the display to represent a fixed amount of charge. A push-button display feature is available for enabling the LED display.

The bq2013H monitors the charge and discharge currents as a voltage across a sense resistor (see R_S in Figure 1). A filter between the negative battery terminal and the SR pin is required.

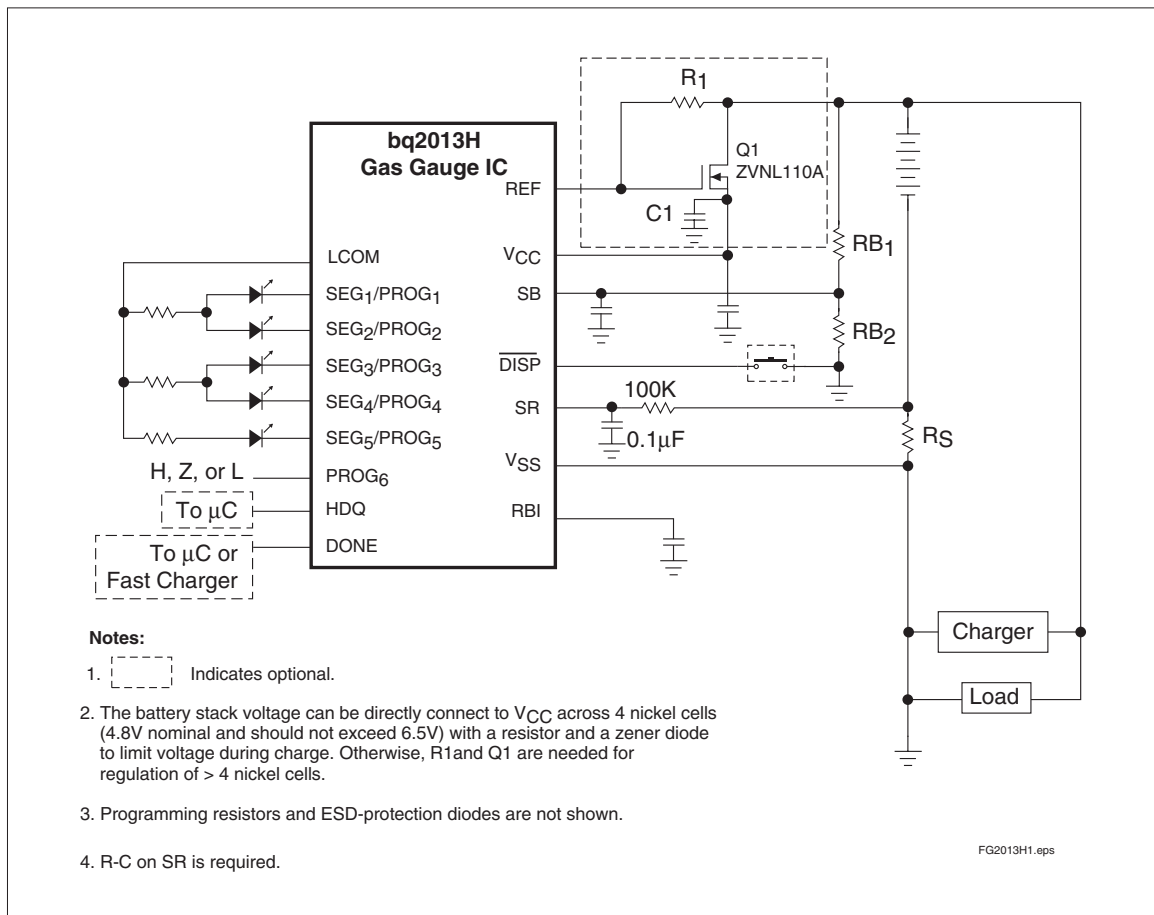

Figure 1. Application Diagram: LED Display

bq2013H

Register Backup

The bq2013H RBI input pin is intended to be used with a storage capacitor to provide backup potential to the internal bq2013H registers when V_{CC} momentarily drops below 3.0V. V_{CC} is output on RBI when V_{CC} is above 3.0V.

After V_{CC} rises above 3.0V, the bq2013H checks the internal registers for data loss or corruption. If data has changed, then the NAC register is cleared, and the LMD register is loaded with the initial PFC.

Voltage Thresholds

In conjunction with monitoring V_{SR} for charge/discharge currents, the bq2013H monitors the battery potential through the SB pin for the end-of-discharge voltage (EDV) thresholds.

The EDV threshold levels are used to determine when the battery has reached an “empty” state.

The EDV thresholds for the bq2013H are set as follows:

$$\text{EDV1 (first)} = 1.00\text{V}$$

$$\text{EDVF (final)} = \text{EDV1} - 100\text{mV}$$

The battery voltage divider (RB1 and RB2 in Figure 1) is used to scale these values to the desired threshold.

If VSB is below either of the two EDV thresholds for the specified delay times in Table 1, the associated flag is latched and remains latched, independent of VSB, until the next valid charge. EDV monitoring is disabled if the OVLD bit in FLGS2 is set.

Table 1. Delay Time in Seconds

| Capacity | Temperature | | |
|------------|-------------|--------------|--------|
| | < 10°C | 10°C to 30°C | > 30°C |
| > 40% | 7 | 6 | 5 |
| 20% to 40% | 4 | 3 | 2 |
| < 20% | 2 | 2 | 2 |

Reset

The bq2013H can be reset by removing V_{CC} and grounding the RBI pin for 15 seconds or with a command over the serial port. The serial port reset command sequence requires writing 00h to register PFC (address = 1eh) and the writing 00h to register LMD (address = 05h.)

Temperature

The bq2013H internally determines the temperature in 10°C steps centered from -35°C to +85°C. The temperature steps are used to adapt charge rate compensations and self-discharge counting. The temperature range is available over the serial port in 10°C increments as shown in the following table:

| TMPGG (hex) | Temperature Range |
|-------------|-------------------|
| 0x | < -30°C |
| 1x | -30°C to -20°C |
| 2x | -20°C to -10°C |
| 3x | -10°C to 0°C |
| 4x | 0°C to 10°C |
| 5x | 10°C to 20°C |
| 6x | 20°C to 30°C |
| 7x | 30°C to 40°C |
| 8x | 40°C to 50°C |
| 9x | 50°C to 60°C |
| Ax | 60°C to 70°C |
| Bx | 70°C to 80°C |
| Cx | > 80°C |

Layout Considerations

The bq2013H measures the voltage differential between the SR and V_{SS} pins. V_{OS} (the offset voltage at the SR pin) is greatly affected by PC board layout. For optimal results, the PC board layout should follow the strict rule of a single-point ground return. Sharing high-current ground with small signal ground causes undesirable noise on the small signal nodes. Additionally:

- The capacitors should be placed as close as possible to the SB and V_{CC} pins and their paths to V_{SS} should be as short as possible. A high-quality ceramic capacitor of 0.1 μf is recommended for V_{CC} .
- The sense resistor (R_S) should be as close as possible to the bq2013H.
- The R-C on the SR pin should be located as close as possible to the SR pin. The maximum R should not exceed 100K.

Gas Gauge Operation

The operational overview diagram in Figure 2 illustrates the operation of the bq2013H. The bq2013H accumulates a measure of charge and discharge currents, as well as an estimation of self-discharge. The bq2013H compensates charge current for charge rate and tem-

perature. Discharge current is load compensated based on the value stored in location LCOMP (address = 0eh). LCOMP allows the bq2013H to automatically adjust for continuous small discharge currents. The bq2013H compensates self discharge for the load value as well as temperature.

The main counter, Nominal Available Capacity (NAC), represents the available battery capacity at any given time. Battery charging increments the NAC register, while battery discharging, self-discharge decrement the NAC register and increment the DCR (Discharge Count Register). NAC is also corrected automatically for offset error based on the value in the offset location OFFSET (address = 0bh.)

The Discharge Count Register (DCR) is used to update the Last Measured Discharge (LMD) register only if a complete battery discharge from full to empty occurs without any partial battery charges. Therefore, the bq2013H adapts its capacity determination based on the actual conditions of discharge.

The battery's initial capacity is equal to the Programmed Full Count (PFC) shown in Table 2. Until LMD is updated, NAC counts up to but not beyond this threshold during subsequent charges. This approach allows the gas gauge to be charger-independent and compatible with any type of charge regime.

1. Last Measured Discharge (LMD) or learned battery capacity:

LMD is the last measured discharge capacity of the battery. On initialization (application of V_{CC} or battery replacement), $LMD = PFC$. During subsequent discharges, the LMD is updated with the latest measured capacity in the Discharge Count Register (DCR) representing a discharge from full to below EDV. The maximum decrease in LMD because of a DCR update is 25% of LMD. A qualified discharge is necessary for a capacity transfer from the DCR to the LMD register. The LMD also serves as the 100% reference threshold used by the relative display mode.

2. Programmed Full Count (PFC) or initial battery capacity:

The initial LMD and gas gauge rate values are programmed by using PFC. The PFC also provides the 100% reference for the absolute display mode. The bq2013H is configured for a given application by selecting a PFC value from Table 2. The correct PFC may be determined by multiplying the rated battery capacity in mAh by the sense resistor value:

$$\text{Battery capacity (mAh)} * \text{sense resistor } (\Omega) =$$

$$\text{PFC (mVh)}$$

Selecting a PFC slightly less than the rated capacity for absolute mode provides capacity above the full reference for much of the battery's life.

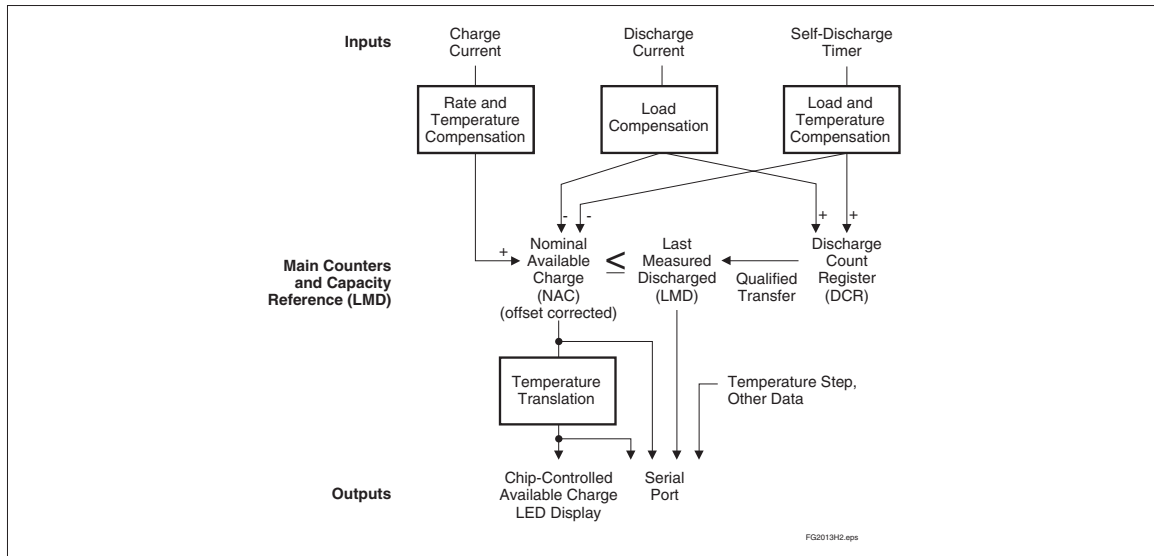

Figure 2. Operational Overview

bq2013H

Example: Selecting a PFC Value

Given:

Sense resistor = 0.0075Ω
 Number of cells = 14
 Capacity = 5000mAh, NiCd cells
 Current range = 1A to 30A
 Relative display mode with 4 second timer
 Self-discharge = 1% per day
 Trickle charge compensation = 0.85
 Typical offset = -75μV
 Voltage drop across sense resistor = 5mV to 225 mV

Therefore:

$$5000\text{mAh} * 0.0075\Omega = 37.5\text{mVh}$$

Select:

PFC = 44,800 counts or 35mVh
 PROG₁, PROG₂ = Z, L
 PROG₃ = Z
 PROG₄ = H
 PROG₅ = L
 PROG₆ = Z

Table 2. bq2013H Programmed Full Count mVh Selections

| Programmed Full Count (PFC) | mVh | Scale | PROG ₁ | PROG ₂ |
|-----------------------------|------|--------|-------------------|-------------------|
| 27136 | 84.8 | 1/320 | H | H |
| 24064 | 75.2 | 1/320 | H | Z |
| 41472 | 64.8 | 1/640 | H | L |
| 35072 | 54.8 | 1/640 | Z | H |
| 28672 | 44.8 | 1/640 | Z | Z |
| 44800 | 35 | 1/1280 | Z | L |
| 30720 | 24 | 1/1280 | L | H |
| 38400 | 15 | 1/2560 | L | Z |
| 12800 | 5 | 1/2560 | L | L |

Table 3. Programmed Self-Discharge

| PROG ₃ | Self-Discharge |
|-------------------|----------------|
| H | 1.6% per day |
| Z | 0.8% per day |
| L | 0.2% per day |

Table 4. Programmed Display Mode

| PROG ₄ | Overload Threshold | Display Mode |
|-------------------|---------------------------|---|
| H | V _{OVLD} = -75mV | Relative/4s timer after push-button release |
| Z | V _{OVLD} = -75mV | Relative/4s timer after push-button release |
| L | V _{OVLD} = -25mV | Absolute/4s timer after push-button release |

Table 5. Programmed Charge Compensation

| PROG ₅ | Trickle | | | Fast | | |
|-------------------|---------|-----------|-------|-------|-----------|-------|
| | <30°C | 30°C—50°C | >50°C | <30°C | 30°C—50°C | >50°C |
| H | 0.80 | 0.75 | 0.70 | 0.95 | 0.90 | 0.85 |
| Z | 1.00 | 1.00 | 1.00 | 1.00 | 1.00 | 1.00 |
| L | 0.85 | 0.80 | 0.75 | 0.95 | 0.90 | 0.85 |

Table 6. Programmed Discharge Offset Adjustment

| PROG ₆ | Offset |
|-------------------|--------|
| H | -150μV |
| Z | -75μV |
| L | 0μV |

bq2013H

The initial full battery capacity is 35mVh (4667mAh) until the bq2013H “learns” a new capacity with a qualified discharge from full to EDV1.

3. Nominal Available Capacity (NAC):

NAC counts up during charge to a maximum value of LMD and down during discharge and self-discharge to 0. NAC is reset to 0 on initialization and on the first valid charge following discharge to EDV1. To prevent overstatement of charge during periods of overcharge, NAC stops incrementing when NAC = LMD. When the DONE input is asserted high, indicating full charge completion, NAC is set to LMD.

4. Discharge Count Register (DCR):

The DCR counts up during discharge independent of NAC and could continue increasing after NAC has decremented to 0. Prior to NAC = 0 (empty battery), both discharge and self-discharge increment the DCR. After NAC = 0, only discharge increments the DCR. The DCR resets to 0 when NAC = LMD. The DCR does not roll over but stops counting when it reaches FFFFh.

The DCR value becomes the new LMD value on the first charge after a valid discharge to EDV1 if all of the following conditions are met:

- No valid charge initiations (charges greater than 2 NAC updates) occurred during the period between NAC = LMD and EDV1.
- The self-discharge count is less than 6% of NAC.
- The temperature is $\geq 0^{\circ}\text{C}$ when the EDV1 level is reached during discharge.
- VDQ is set.

Charge Counting

Charge activity is detected based on a positive voltage on the V_{SR} input. If charge activity is detected, the bq2013H increments NAC at a rate proportional to V_{SRO} ($V_{SR} + V_{OS}$) and, if enabled, activates an LED display if $V_{SRO} > 500\mu\text{V}$. Charge actions increment the NAC after compensation for charge rate and temperature.

The bq2013H detects charge activity with $V_{SRO} > 250\mu\text{V}$. A valid charge equates to a sustained charge activity greater than 2 NAC updates. Once a valid charge is detected, charge counting continues until V_{SRO} drops below $250\mu\text{V}$.

Discharge Counting

All discharge counts where $V_{SRO} < -250\mu\text{V}$ cause the NAC register to decrement and the DCR to increment. If enabled, the display is activated when $V_{SRO} < -2\text{mV}$. The display remains active for 10 seconds after V_{SRO} rises above -2mV .

Self-Discharge Estimation

The bq2013H decrements NAC and increments DCR for self-discharge based on time and temperature. The self-discharge count rate is programmed per Table 3. This is the rate for a battery temperature between $20\text{--}30^{\circ}\text{C}$. The NAC register cannot be decremented below 0.

Count Compensations

The bq2013H determines fast charge when the NAC updates at a rate of ≥ 2 counts/s. Charge activity is compensated for temperature and rate before updating NAC. Self-discharge estimation is compensated for temperature before updating NAC or DCR.

Charge Compensation

Charge efficiency factors are selected using Table 5 for trickle charge and fast charge. Fast charge is defined as a rate of charge resulting in ≥ 2 NAC counts/s (0.16C to 0.6C , depending on PFC selections; see Table 2).

Temperature adapts the charge rate compensation factors over three ranges between nominal, warm, and hot temperatures. Program pin 5 is used to select one of three compensation programs. These values are shown in Table 5.

Self-Discharge Compensation

The self-discharge compensation can be programmed for three different rates. The rates vary across 8 ranges from $<10^{\circ}\text{C}$ to $>70^{\circ}\text{C}$, doubling with each higher temperature step (10°C). See Table 7.

Table 7. Self-Discharge Compensation

| Temperature Range | Self-Discharge Compensation Typical Rate/Day | | |
|---------------------------------|--|-----------------------|-----------------------|
| | PROG ₃ = H | PROG ₃ = Z | PROG ₃ = L |
| $< 10^{\circ}\text{C}$ | NAC/ ₂₅₆ | NAC/ ₆₁₂ | NAC/ ₂₀₄₈ |
| $10\text{--}20^{\circ}\text{C}$ | NAC/ ₁₂₈ | NAC/ ₂₅₆ | NAC/ ₁₀₂₄ |
| $20\text{--}30^{\circ}\text{C}$ | NAC/ ₆₄ | NAC/ ₁₂₈ | NAC/ ₅₁₂ |
| $30\text{--}40^{\circ}\text{C}$ | NAC/ ₃₂ | NAC/ ₆₄ | NAC/ ₂₅₆ |
| $40\text{--}50^{\circ}\text{C}$ | NAC/ ₁₆ | NAC/ ₃₂ | NAC/ ₁₂₈ |
| $50\text{--}60^{\circ}\text{C}$ | NAC/ ₈ | NAC/ ₁₆ | NAC/ ₆₄ |
| $60\text{--}70^{\circ}\text{C}$ | NAC/ ₄ | NAC/ ₈ | NAC/ ₃₂ |
| $> 70^{\circ}\text{C}$ | NAC/ ₂ | NAC/ ₄ | NAC/ ₁₆ |

Offset Compensation

The bq2013H uses a voltage to frequency converter to measure the voltage across a resistor used to monitor the current into and out of the battery. This converter has an offset value that can be influenced by the V_{CC} supply and the bypassing of this supply. The typical value found on a well designed PCB is about $-75\mu\text{V}$. Program pin 6 can be used to compensate for this offset, reducing the effective V_{OS} . Offset compensation occurs when $V_{\text{SRO}} < -250\mu\text{V}$ or $V_{\text{SRO}} > 250\mu\text{V}$.

Error Summary

The LMD is susceptible to error on initialization or if no updates occur. On initialization, the LMD value includes the error between the programmed full capacity and the actual capacity. This error is present until a valid discharge occurs and LMD is updated (see the DCR description in the “Layout Considerations” section). The other cause of LMD error is battery wear-out. As the battery ages, the measured capacity must be adjusted to account for changes in actual battery capacity.

DONE Input

A fast-charge controller IC or micro-controller uses the DONE input to communicate charge status to the bq2013H. When the DONE input is asserted high on

fast-charge completion, the bq2013H sets NAC = LMD and VDQ = 1. The DONE input should be maintained high as long as the fast-charge controller or microcontroller keeps the batteries full; otherwise the pin should be held low.

Communicating With the bq2013

The bq2013H includes a simple single-pin (HDQ plus return) serial data interface. A host processor uses the interface to access various bq2013H registers. Battery characteristics may be easily monitored by adding a single contact to the battery pack. The open-drain HDQ pin on the bq2013H should be pulled up by the host system, or may be left floating if the serial interface is not used.

The interface uses a command-based protocol, where the host processor sends a command byte to the bq2013H. The command directs the bq2013H to either store the next eight bits of data received to a register specified by the command byte or output the eight bits of data specified by the command byte. (See Figure 3.)

The communication protocol is asynchronous return-to-one. Command and data bytes consist of a stream of eight bits that have a maximum transmission rate of 5K bits/s. The least-significant bit of a command or data byte is transmitted first. The protocol is simple enough that it can be implemented by most host processors using either polled or interrupt processing. Data input from the bq2013H may be sampled using the pulse-width capture timers available on some microcontrollers.

If a communication error occurs, e.g., $t_{\text{CYCB}} > 250\mu\text{s}$, the bq2013H should be sent a BREAK to reinitiate the serial interface. A BREAK is detected when the HDQ pin is driven to a logic-low state for a time, t_{B} or greater. The HDQ pin should then be returned to its normal ready-high logic state for a time, t_{BR} . The bq2013H is now ready to receive a command from the host processor.

The return-to-one data bit frame consists of three distinct sections. The first section is used to start the transmission by either the host or the bq2013H taking the HDQ pin to a logic-low state for a period, $t_{\text{STRH,B}}$. The next section is the actual data transmission, where the data should be valid by a period, $t_{\text{DSU,B}}$, after the negative edge used to start communication. The data should be held for a period, t_{DHDV} , to allow the host or bq2013H to sample the data bit.

The final section is used to stop the transmission by returning the HDQ pin to a logic-high state by at least a period, $t_{\text{SSU,B}}$, after the negative edge used to start communication. The final logic-high state should be until a period $t_{\text{CYCH,B}}$, to allow time to ensure that the bit transmission was stopped properly. The timings for data and break communication are given in the serial com-

bq2013H

Table 8. bq2013H Current-Sensing Errors

| Symbol | Parameter | Typical | Maximum | Units | Notes |
|--------|------------------------------------|---------|---------|-------|---|
| INL | Integrated non-linearity error | ± 2 | ± 4 | % | Add 0.1% per °C above or below 25°C and 1% per volt above or below 4.25V. |
| INR | Integrated non-repeatability error | ± 1 | ± 2 | % | Measurement repeatability given similar operating conditions. |

munication timing specification and illustration sections.

Communication with the bq2013H is always performed with the least-significant bit being transmitted first. Figure 3 shows an example of a communication sequence to read the bq2013H NACH register.

bq2013H Command Code and Registers

The bq2013H status registers are listed in Table 9 and described below.

Command Code

The bq2013H latches the command code when eight valid command bits have been received by the bq2013H. The command code register contains two fields:

- W/\bar{R} bit
- Command address

The W/\bar{R} bit of the command code is used to select whether the received command is for a read or a write function.

The W/\bar{R} location is:

| Command Code Bits | | | | | | | |
|-------------------|---|---|---|---|---|---|---|
| 7 | 6 | 5 | 4 | 3 | 2 | 1 | 0 |
| W/\bar{R} | - | - | - | - | - | - | - |

Where W/\bar{R} is:

- 0 The bq2013H outputs the requested register contents specified by the address portion of command code.
- 1 The following eight bits should be written to the register specified by the address portion of command code.

The lower seven-bit field of command code contains the address portion of the register to be accessed. Attempts to write to invalid addresses are ignored.

| Command Code Bits | | | | | | | |
|-------------------|-----|-----|-----|-----|-----|-----|-----------|
| 7 | 6 | 5 | 4 | 3 | 2 | 1 | 0 |
| - | AD6 | AD5 | AD4 | AD3 | AD2 | AD1 | AD0 (LSB) |

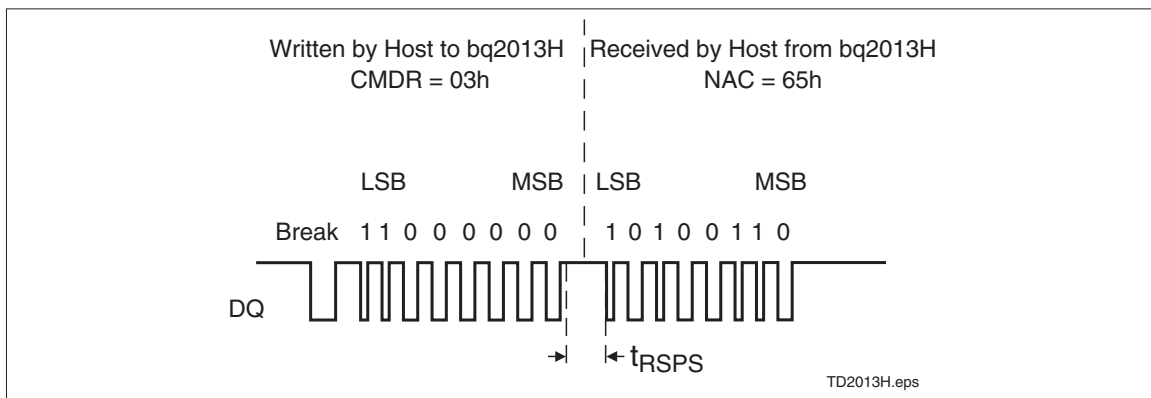

Figure 3. Typical Communication With the bq2013H

Table 9. bq2013H Command and Status Registers

| Symbol | Register Name | Loc. (hex) | Read/Write | Control Field | | | | | | | |
|--------|---|------------|------------|---------------|--------|--------|--------|--------|--------|--------|--------|
| | | | | 7(MSB) | 6 | 5 | 4 | 3 | 2 | 1 | 0(LSB) |
| FLGS1 | Primary status flags register | 01h | R | CHGS | BRP | RSVD | RSVD | VDQ | RSVD | EDV1 | EDVF |
| TMPGG | Temperature and gas gauge register | 02h | R | TMP3 | TMP2 | TMP1 | TMP0 | GG3 | GG2 | GG1 | GG0 |
| NACH | Nominal available capacity high byte register | 03h | R/W | NACH7 | NACH6 | NACH5 | NACH4 | NACH3 | NACH2 | NACH1 | NACH0 |
| NACL | Nominal available capacity low byte register | 17h | R/W | NACL7 | NACL6 | NACL5 | NACL4 | NACL3 | NACL2 | NACL1 | NACL0 |
| BATID | Battery identification register | 04h | R/W | BATID7 | BATID6 | BATID5 | BATID4 | BATID3 | BATID2 | BATID1 | BATID0 |
| LMD | Last measured discharge register | 05h | R/W | LMD7 | LMD6 | LMD5 | LMD4 | LMD3 | LMD2 | LMD1 | LMD0 |
| FLGS2 | Secondary status flags register | 06h | R | CR | RSVD | RSVD | RSVD | RSVD | RSVD | RSVD | OVLDD |
| PPD | Program pull down register | 07h | R | RSVD | RSVD | PPD6 | PPD5 | PPD4 | PPD3 | PPD2 | PPD1 |
| PPU | Program pull up register | 08h | R | RSVD | RSVD | PPU6 | PPU5 | PPU4 | PPU3 | PPU2 | PPU1 |
| OCTL | Output control register | 0ah | R/W | OC6 | OC5 | OC4 | OC3 | OC2 | OC1 | OCE | OCC |
| OFFSET | Offset adjustment register | 0bh | R/W | OFS7 | OFS6 | OFS5 | OFS4 | OFS3 | OFS2 | OFS1 | OFS0 |
| SDR | Self discharge rate | 0ch | R/W | SDR7 | SDR6 | SDR5 | SDR4 | SDR3 | SDR2 | SDR1 | SDR0 |
| DMF | Digital magnitude filter | 0dh | R/W | DMF7 | DMF6 | DMF5 | DMF4 | DMF3 | DMF2 | DMF1 | DMF0 |
| LCOMP | Load compensation | 0eh | R/W | LC7 | LC6 | LC5 | LC4 | LC3 | LC2 | LC1 | LC0 |
| CCOMP | Fast charge compensation | 0fh | R/W | CC7 | CC6 | CC5 | CC4 | CC3 | CC2 | CC1 | CC0 |
| PPFC | Program pin data | 1eh | R/W | RSVD | RSVD | RSVD | RSVD | RSVD | RSVD | RSVD | RSVD |
| VSB | Battery voltage register | 7eh | R | VSB7 | VSB6 | VSB5 | VSB4 | VSB3 | VSB2 | VSB1 | VSB0 |

Notes: RSVD = reserved.
All other registers not documented are reserved.

bq2013H

Primary Status Flags Register (FLGS1)

The FLGS1 register (address=01h) contains the primary bq2013H flags.

The **charge status** flag (CHGS) is asserted when a valid charge rate is detected. The bq2013H deems the charge valid if it results in two NAC updates with $V_{SRO} > 250\mu V$. A V_{SRO} of less than $250\mu V$ or discharge activity clears CHGS.

The CHGS location is:

| FLGS1 Bits | | | | | | | |
|------------|---|---|---|---|---|---|---|
| 7 | 6 | 5 | 4 | 3 | 2 | 1 | 0 |
| CHGS | - | - | - | - | - | - | - |

where CHGS is

- 0 Either discharge activity detected or $V_{SRO} < 250\mu V$
- 1 Two NAC updates with $V_{SRO} > 250\mu V$

The **battery replaced** flag (BRP) is asserted whenever the bq2013H is reset by application of V_{CC} or by a serial port command. BRP is reset when either a valid charge action increments NAC to be equal to LMD, or when a valid charge action is detected after the EDV1 flag is asserted. BRP = 1 signifies that the device has been reset.

The BRP location is:

| FLGS1 Bits | | | | | | | |
|------------|-----|---|---|---|---|---|---|
| 7 | 6 | 5 | 4 | 3 | 2 | 1 | 0 |
| - | BRP | - | - | - | - | - | - |

where BRP is

- 0 bq2013H is charged until NAC = LMD or on the first charge after a discharge which sets the EDV1 flag
- 1 bq2013H is reset

The **valid discharge** flag (VDQ) is asserted when the bq2013H is discharged from NAC=LMD. The flag remains set until either LMD is updated or until one of three actions that can clear VDQ occurs:

- NAC has been reduced by more than 6% during because of self-discharge since VDQ was set
- A valid charge action sustained at $V_{SRO} > V_{SRQ}$ for at least two NAC updates
- The EDV1 flag was set at a temperature below $0^{\circ}C$.

The VDQ location is:

| FLGS1 Bits | | | | | | | |
|------------|---|---|---|-----|---|---|---|
| 7 | 6 | 5 | 4 | 3 | 2 | 1 | 0 |
| - | - | - | - | VDQ | - | - | - |

where VDQ is

- 0 Self-discharge reduces NAC by 6%, valid charge action detected, EDV1 asserted with the temperature less than $0^{\circ}C$, or reset
- 1 On first discharge after NAC = LMD

The first **end-of-discharge warning** flag (EDV1) warns the user that the battery is empty. SEG1 blinks at a 4Hz rate and DONE is asserted low. EDV1 detection is disabled if OVLD = 1. The EDV flag is latched until a valid charge has been detected.

The EDV1 location is:

| FLGS1 Bits | | | | | | | |
|------------|---|---|---|---|---|------|---|
| 7 | 6 | 5 | 4 | 3 | 2 | 1 | 0 |
| - | - | - | - | - | - | EDV1 | - |

where EDV1 is

- 0 Valid charge action detected or $V_{SB} \geq V_{EDV1}$
- 1 $V_{SB} < V_{EDV1}$ for the delay time, provided that the OVLD bit is not set

The **final end-of-discharge warning** flag (EDVF) flag is used to warn that battery power is at a failure condition. All segment drivers are turned off. The EDVF flag is latched until a valid charge has been detected. The EDVF threshold is set 100mV below the EDV1 threshold.

The EDVF location is:

| FLGS1 Bits | | | | | | | |
|------------|---|---|---|---|---|---|------|
| 7 | 6 | 5 | 4 | 3 | 2 | 1 | 0 |
| - | - | - | - | - | - | - | EDVF |

Where EDVF is:

- 0 Valid charge action detected or $V_{SB} \geq V_{EDVF}$
- 1 $V_{SB} < V_{EDVF}$, providing the OVLD bit is not set

Table 10. Temperature Register Contents

| TMP3 | TMP2 | TMP1 | TMP0 | Temperature |
|------|------|------|------|-------------------|
| 0 | 0 | 0 | 0 | T < -30°C |
| 0 | 0 | 0 | 1 | -30°C < T < -20°C |
| 0 | 0 | 1 | 0 | -20°C < T < -10°C |
| 0 | 0 | 1 | 1 | -10°C < T < 0°C |
| 0 | 1 | 0 | 0 | 0°C < T < 10°C |
| 0 | 1 | 0 | 1 | 10°C < T < 20°C |
| 0 | 1 | 1 | 0 | 20°C < T < 30°C |
| 0 | 1 | 1 | 1 | 30°C < T < 40°C |
| 1 | 0 | 0 | 0 | 40°C < T < 50°C |
| 1 | 0 | 0 | 1 | 50°C < T < 60°C |
| 1 | 0 | 1 | 0 | 60°C < T < 70°C |
| 1 | 0 | 1 | 1 | 70°C < T < 80°C |
| 1 | 1 | 0 | 0 | T > 80°C |

Temperature and Gas Gauge Register (TMPGG)

| TMPGG Temperature Bits | | | | | | | |
|------------------------|------|------|------|---|---|---|---|
| 7 | 6 | 5 | 4 | 3 | 2 | 1 | 0 |
| TMP3 | TMP2 | TMP1 | TMP0 | - | - | - | - |

The read-only TMPGG register (address=02h) contains two data fields. The first field contains the battery temperature. The second field contains the available charge from the battery.

The bq2013H contains an internal temperature sensor. The temperature is used to set charge efficiency factors as well as to adjust the self-discharge coefficient. The temperature register contents may be translated as shown in Table 10.

The bq2013H calculates the available charge as a function of NAC and a full reference, either LMD or PFC. The results of the calculation are available via the display port or the gas gauge field of the TMPGG register. The register is used to give available capacity in 1/16 increments from 0 to 15/16.

| TMPGG Gas Gauge Bits | | | | | | | |
|----------------------|---|---|---|-----|-----|-----|-----|
| 7 | 6 | 5 | 4 | 3 | 2 | 1 | 0 |
| - | - | - | - | GG3 | GG2 | GG1 | GG0 |

Nominal Available Charge Register (NAC)

The NACH register (address=03h) and the NACL register (address=17h) are the main gas gauging registers for the bq2013H. The NAC registers are incremented during charge actions and decremented during discharge and self-discharge actions. The correction factors for charge/discharge efficiency are applied automatically to NAC. NACH and NACL are set to 0 during a bq2013H reset.

Battery Identification Register (BATID)

The read/write BATID register (address=04h) is available for use by the system to determine the type of battery pack. The BATID contents are retained as long as V_{RBI} is greater than 2V. The contents of BATID have no effect on the operation of the bq2013H. There is no default setting for this register.

Last Measured Discharge Register (LMD)

LMD is a read/write register (address=05h) that the bq2013H uses as a measured full reference. The bq2013H adjusts LMD based on the measured discharge capacity of the battery from full to empty. In this way the bq2013H updates the capacity of the battery. LMD is set to PFC during a bq2013H reset.

Secondary Status Flags Register (FLGS2)

The read-only FLGS2 register (address=06h) contains the secondary bq2013H flags.

The *charge rate* flag (CR) is used to denote the fast charge regime. Fast charge is assumed whenever a charge action is initiated. The CR flag remains asserted if the charge rate does not fall below 2 NAC counts/s.

The CR location is:

| FLGS2 Bits | | | | | | | |
|------------|---|---|---|---|---|---|---|
| 7 | 6 | 5 | 4 | 3 | 2 | 1 | 0 |
| CR | - | - | - | - | - | - | - |

Where CR is:

- 0 When charge rate falls below 2 counts/sec
- 1 When charge rate is above 2 counts/sec

The fast charge regime efficiency factors are used when CR = 1. When CR = 0, the trickle charge efficiency fac-

bq2013H

tors are used. The time to change CR varies due to the user-selectable count rates.

The **overload** flag (OVL D) is asserted when a discharge overload is detected. PROG4 defines the overload threshold, as defined in Table 4. OVL D remains asserted as long as the condition is valid.

The OVL D location is:

| FLGS2 Bits | | | | | | | |
|------------|---|---|---|---|---|---|-------|
| 7 | 6 | 5 | 4 | 3 | 2 | 1 | 0 |
| - | - | - | - | - | - | - | OVL D |

Where OVL D is:

- 0 If $V_{SRO} > V_{OVL D}$
- 1 If $V_{SRO} < V_{OVL D}$

Program Pin Pull-Down Register (PPD)

The PPD register (address=07h) contains some of the programming pin information for the bq2013H. The program pins have a corresponding PPD bit location, PPD₁₋₆. A given location is set if a pull-down resistor has been detected on its corresponding segment driver. For example, if PROG₁ and PROG₄ have pull-down resistors, the contents of PPD are xx001001.

| PPD/PPU Bits | | | | | | | |
|--------------|------|------------------|------------------|------------------|------------------|------------------|------------------|
| 7 | 6 | 5 | 4 | 3 | 2 | 1 | 0 |
| RSVD | RSVD | PPU ₆ | PPU ₅ | PPU ₄ | PPU ₃ | PPU ₂ | PPU ₁ |
| RSVD | RSVD | PPD ₆ | PPD ₅ | PPD ₄ | PPD ₃ | PPD ₂ | PPD ₁ |

Program Pin Pull-Up Register (PPU)

The PPU register (address=08h) contains the rest of the programming pin information for the bq2013H. The program pins have a corresponding PPU bit location, PPU₁₋₆. A given location is set if a pull-up resistor has been detected on its corresponding segment driver. For example, if PROG₃ and PROG₅ have pull-up resistors, the contents of PPU are xx010100.

Output Control Register (OCTL)

The write-only OCTL register (address=0ah) provides the system with a means to check the display connections for the bq2013H. The segment drivers may be overwritten by data from OCTL when bit 1 of OCTL, OCE, is set. The data in bits OC₅₋₁ of the OCTL register (see Table 9 for details) is output onto the segment pins, SEG₅₋₁, respectively if OCE=1. *Whenever OCE is written to 1, the MSB of OCTL should be set to a 1.* The OCE register location must be cleared to return the bq2013H to normal opera-

tion. OCE may be cleared by either writing the bit to a logic zero via the serial port or by resetting the bq2013H.

Offset Adjustment Register

The value in this register (address = 0bh) is used to correct NAC for the offset of the VFC. This register is initialized from the state of PROG₆. The following are the initial values:

- 0 = no offset correction
- 46 = -75μV correction
- 23 = -150μV correcton

The value is set by the equation:

$$\text{Offset} = \frac{1}{289 * V_{COS}}$$

where V_{COS} is the desired offset correction in volts.

Self-Discharge Rate Compensation

This register contains the value used to correct for the self-discharge compensation. This value is initialized from the state of PROG₃. The following are the initial values:

- 235 = 1.6% per day $\left(\frac{1}{64}\right)$
- 214 = 0.8% per day $\left(\frac{1}{128}\right)$
- 88 = 0.2% per day $\left(\frac{1}{512}\right)$

The value is set by the equation:

$$\text{SDR} = 256 - \left(\frac{0.3296}{C_{SD}}\right)$$

where C_{SD} is the self-discharge rate per day.

Digital Magnitude Filter (DMF)

The read-write DMF register (address=0dh) provides the system with a means to change the default settings of the digital magnitude filter. By writing different values into this register, the limits of V_{SRD} and V_{SRQ} can be adjusted. The default value for the DMF is 250μV. The value is set by the equation:

$$\text{DMF} = \frac{45}{V_{SRD,Q}}$$

where $V_{SRD,Q}$ is the desired filter threshold in mV.

Note: Care should be taken when writing to this register. A V_{SRD} and V_{SRQ} below the specified V_{OS} may adversely affect the accuracy of the bq2013H.

Load Compensation

The load compensation value (address = 0eh) allows the bq2013H to compensate for small discharge loads that are below the digital filter. Each increment in the LCOMP register represents 2 μ Vh. The value in LCOMP represents the additional amount of discharge applied to NAC and DCR at a constant rate when $V_{SRO} < V_{SRQ}$. LCOMP compensation is applied in addition to self-discharge. LCOMP is set to 0 on a full reset. The value is set by the equation:

$$LCOMP = \frac{1}{289 * V_{CLD}}$$

where V_{CLD} is the desired load correction in volts.

Charge Compensation

The charge-compensation value (address = 0fh) allows the bq2013H to compensate for battery charge inefficiencies. This value is initialized from the state of PROG₅ and represents the fast-charge compensation factor for < 30°C. The value can be overwritten via the serial port and is stored in percent. The bq2013H scales the value in 0fh to determine the compensation at other rates and temperatures. For example, if PROG₅ = H, the applied efficiency drops by 5% for each temperature range, and the trickle rates are 15% below the fast-charge rates. If the value 55h (85%) is written to CCOMP, the compensation for trickle charge at > 50°C is 60%.

Program Pin Data (PPFC)

The PPFC register provides the means to perform a software controlled reset of the device. The recommended reset method for the bq2013H is:

- Write PPFC to zero
- Write LMD to zero

After these operations, a software reset occurs.

Resetting the bq2013H sets the following:

- LMD = PFC
- VDQ, OCE, LCOMP, and NAC = 0
- BRP = 1

Battery Voltage Register (VSB)

The battery voltage register is used to read the battery voltage on the SB pin. The VSB register (address = 7eh) is updated approximately once per second with the present value of the battery voltage. The battery voltage on the SB pin is determined by the equation:

$$V_{SB} = 1.2V * \left(\frac{V_{SB}}{256} \right)$$

Display

The bq2013H can directly display capacity information using low-power LEDs. If LEDs are used, the segment pins should be tied to V_{CC} , the battery, or the LCOM pin through resistors for programming the bq2013H.

The bq2013H displays the battery charge state in either absolute or relative mode. In relative mode, the battery charge is represented as a percentage of the LMD. Each LED segment represents 20% of the LMD.

In absolute mode, each segment represents a fixed amount of charge, based on the initial PFC. In absolute mode, each segment represents 20% of the PFC. As the battery wears out over time, it is possible for the LMD to be below the initial PFC. In this case, all of the LEDs may not turn on, representing the reduction in the actual battery capacity.

When \overline{DISP} is tied to V_{CC} , the SEG₁₋₅ outputs are inactive. When \overline{DISP} is left floating, the display becomes active during charge if the NAC registers are counting at a rate equivalent to $V_{SRO} > 500\mu V$ or fast discharge if the NAC registers are counting at a rate equivalent to $V_{SRO} < -2mV$. When \overline{DISP} is pulled low and held, the segment outputs become active continuously. When released to high Z, the segment outputs will remain active for 4 seconds.

The segment outputs are modulated as two banks, with segments 1, 3, and 5 alternating with segments 2 and 4. The segment outputs are modulated at approximately 320Hz, with each bank active for 30% of the period.

SEG₁ blinks at a 4Hz rate whenever V_{SB} has been detected to be below V_{EDV1} to indicate a low-battery condition or NAC is less than 10% of the LMD or PFC, depending on the display mode.

Microregulator

The bq2013H can operate directly from 4 nickel or 3 lead acid cells. To facilitate the power supply requirements of the bq2013H, an REF output is provided to regulate an external low-threshold n-FET. A micropower source for the bq2013H can be inexpensively built using the FET and an external resistor.

bq2013H

Absolute Maximum Ratings

| Symbol | Parameter | Minimum | Maximum | Unit | Notes |
|------------------|-----------------------------|---------|----------------------|------|--|
| V _{CC} | Relative to V _{SS} | -0.3 | +7.0 | V | |
| All other pins | Relative to V _{SS} | -0.3 | +7.0 | V | |
| REF | Relative to V _{SS} | -0.3 | +8.5 | V | Current limited by R1 (see Figure 1) |
| V _{SR} | Relative to V _{SS} | -0.3 | V _{CC} +0.7 | V | 100kΩ series resistor should be used to protect SR in case of a shorted battery. |
| T _{OPR} | Operating temperature | 0 | +70 | °C | Commercial |

Note: Permanent device damage may occur if **Absolute Maximum Ratings** are exceeded. Functional operation should be limited to the Recommended DC Operating Conditions detailed in this data sheet. Exposure to conditions beyond the operational limits for extended periods of time may affect device reliability.

DC Voltage Thresholds (T_A = T_{OPR}; V = 3.0 to 6.5V)

| Symbol | Parameter | Minimum | Typical | Maximum | Unit | Notes |
|------------------|--------------------------|-------------------------|------------------|-------------------------|------|---------------------------------------|
| V _{EDV} | End-of-discharge warning | 0.96 * V _{EDV} | V _{EDV} | 1.04 * V _{EDV} | V | SB |
| V _{SRO} | SR sense range | -300 | - | +500 | mV | SR, V _{SR} + V _{OS} |
| V _{SRQ} | Valid charge | 250 | - | - | μV | V _{SR} + V _{OS} |
| V _{SRD} | Valid discharge | - | - | -250 | μV | V _{SR} + V _{OS} |

Note: V_{OS} is affected by PC board layout. Proper layout guidelines should be followed for optimal performance. See "LayoutConsiderations."

DC Electrical Characteristics (TA = TOPR)

| Symbol | Parameter | Minimum | Typical | Maximum | Unit | Notes |
|--------------------|--|-----------------------|---------|-----------------------|------|--|
| V _{CC} | Supply voltage | 3.0 | 4.25 | 6.5 | V | V _{CC} excursion from < 2.0V to ≥ 3.0V initializes the unit. |
| V _{OS} | Offset referred to V _{SR} | - | ±50 | ±150 | μV | $\overline{\text{DISP}} = V_{CC}$ |
| V _{REF} | Reference at 25°C | 5.7 | 6.0 | 6.3 | V | I _{REF} = 5μA |
| | Reference at -40°C to +85°C | 4.5 | - | 7.5 | V | I _{REF} = 5μA |
| R _{REF} | Reference input impedance | 2.0 | 5.0 | - | MΩ | V _{REF} = 3V |
| I _{CC} | Normal operation | - | 90 | 135 | μA | V _{CC} = 3.0V, HDQ = 0 |
| | | - | 120 | 180 | μA | V _{CC} = 4.25V, HDQ = 0 |
| | | - | 170 | 250 | μA | V _{CC} = 6.5V, HDQ = 0 |
| V _{SB} | Battery input | 0 | - | V _{CC} | V | |
| R _{SBmax} | SB input impedance | 10 | - | - | MΩ | 0 < V _{SB} < V _{CC} |
| I _{DISP} | $\overline{\text{DISP}}$ input leakage | - | - | 5 | μA | V _{DISP} = V _{SS} |
| I _{LCOM} | LCOM input leakage | -0.2 | - | 0.2 | μA | $\overline{\text{DISP}} = V_{CC}$ |
| I _{RBI} | RBI data-retention current | - | - | 100 | nA | V _{RBI} > V _{CC} < 3V |
| R _{HDQ} | Internal pulldown | 500 | - | - | KΩ | |
| R _{SR} | SR input impedance | 10 | - | - | MΩ | -200mV < V _{SR} < V _{CC} |
| V _{IHPFC} | PROG logic input high | V _{CC} - 0.2 | - | - | V | PROG ₁₋₆ |
| V _{ILPFC} | PROG logic input low | - | - | V _{SS} + 0.2 | V | PROG ₁₋₆ |
| V _{IZPFC} | PROG logic input Z | float | - | float | V | PROG ₁₋₆ |
| V _{OLSL} | SEG output low, low V _{CC} | - | 0.1 | - | V | V _{CC} = 3V, I _{OLS} ≤ 1.75mA SEG ₁ -SEG ₅ , DONE |
| V _{OLSH} | SEG output low, high V _{CC} | - | 0.4 | - | V | V _{CC} = 6.5V, I _{OLS} ≤ 11.0mA SEG ₁ -SEG ₅ , DONE |
| V _{OHML} | LCOM output high, low V _{CC} | V _{CC} - 0.3 | - | - | V | V _{CC} = 3V, I _{OHLCOM} = -5.25mA |
| V _{OHMH} | LCOM output high, high V _{CC} | V _{CC} - 0.6 | - | - | V | V _{CC} > 3.5V, I _{OHLCOM} = -33.0mA |
| I _{OLS} | SEG sink current | 11.0 | - | - | mA | At V _{OLSH} = 0.4V, V _{CC} = 6.5V |
| I _{OL} | Open-drain sink current | 5.0 | - | - | mA | At V _{OL} = V _{SS} + 0.3V, HDQ |
| V _{OL} | Open-drain output low | - | - | 0.3 | V | I _{OL} ≤ 5mA, HDQ |
| V _{IHDQ} | HDQ input high | 2.5 | - | - | V | HDQ |
| V _{ILDQ} | HDQ input low | - | - | 0.8 | V | HDQ |
| V _{IH} | DONE input high | 2.5 | - | - | V | DONE |
| V _{IL} | DONE input low | - | - | 0.5 | V | DONE |
| R _{PROG} | Soft pull-up or pull-down resistor value (for programming) | - | - | 200 | kΩ | PROG ₁₋₆ |
| R _{FLOAT} | Float state external impedance | - | 5 | - | MΩ | PROG ₁₋₆ |

Note: All voltages relative to V_{SS}.

bq2013H

High-Speed Serial Communication Timing Specification (TA = TOPR)

| Symbol | Parameter | Minimum | Typical | Maximum | Unit | Notes |
|--------|-------------------------------------|---------|---------|---------|------|----------|
| tCYCH | Cycle time, host to bq2013H (write) | 190 | - | - | μs | See note |
| tCYCB | Cycle time, bq2013H to host (read) | 190 | 205 | 250 | μs | |
| tSTRH | Start hold, host to bq2013H (write) | 5 | - | - | ns | |
| tSTRB | Start hold, bq2013H to host (read) | 32 | - | - | μs | |
| tDSU | Data setup | - | - | 50 | μs | |
| tDSUB | Data setup | - | - | 50 | μs | |
| tDH | Data hold | 100 | - | - | μs | |
| tDV | Data valid | 80 | - | - | μs | |
| tSSU | Stop setup | - | - | 145 | μs | |
| tSSUB | Stop setup | - | - | 145 | μs | |
| tRSPS | Response time, bq2013H to host | 190 | - | 320 | μs | |
| tB | Break | 190 | - | - | μs | |
| tBR | Break recovery | 40 | - | - | μs | |

Note: The open-drain HDQ pin should be pulled to at least V_{CC} by the host system for proper HDQ operation. HDQ may be left floating if the serial interface is not used.

Break Timing

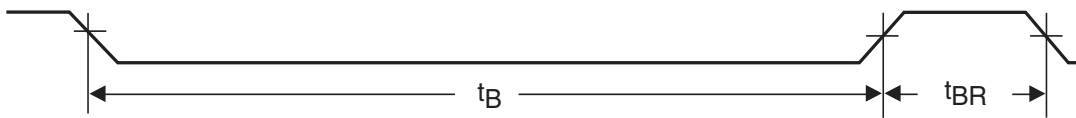

TD201803.eps

Host to bq2013H

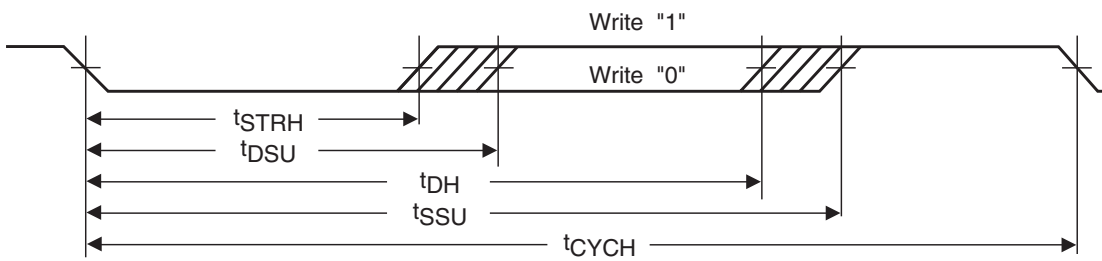

bq2013H to Host

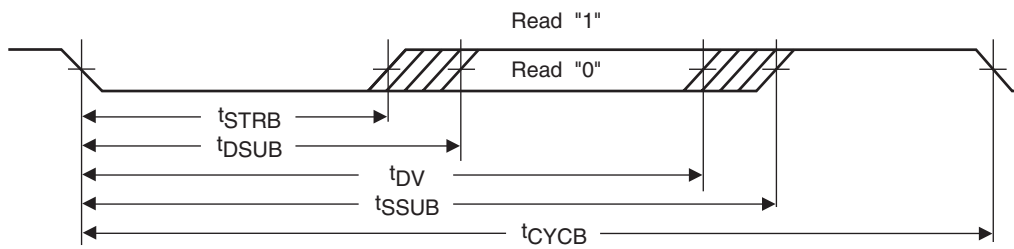

16-Pin SOIC Narrow (SN)

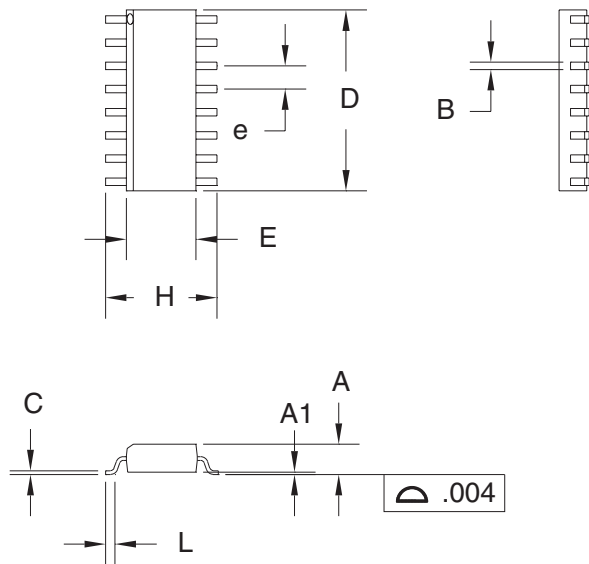

16-Pin SN (SOIC Narrow)

| Dimension | Minimum | Maximum |
|-----------|---------|---------|
| A | 0.060 | 0.070 |
| A1 | 0.004 | 0.010 |
| B | 0.013 | 0.020 |
| C | 0.007 | 0.010 |
| D | 0.385 | 0.400 |
| E | 0.150 | 0.160 |
| e | 0.045 | 0.055 |
| H | 0.225 | 0.245 |
| L | 0.015 | 0.035 |

All dimensions are in inches.

Data Sheet Revision History

| ChangeNo. | Page No. | Description of Change |
|-----------|----------|--|
| 1 | All | "Final" changes from "Preliminary" version |
| 2 | 3 | Updated application diagram |
| 2 | 8 | Changed charge/discharge default threshold from 200 μ V to 250 μ V. |
| 2 | 9 | Changed offset compensation window range from \pm 200 μ V to \pm 250 μ V |
| 2 | 11 | Designated appropriate locations from "R/W" to "R" |
| 2 | 12 | Changed charge threshold from 200 μ V to 250 μ V |
| 2 | 14 | Changed default DMF from 200 μ V to 250 μ V |
| 2 | 16 | Added REF absolute maximum rating |
| 2 | 16 | Changed charge/discharge default threshold from 200 μ V to 250 μ V |
| 2 | 16 | Added VSRO parameter |
| 2 | 17 | Changed DQ designation to HDQ |
| 2 | 17 | Changed V _{OL} from 0.5V to 0.3V (max.) |
| 2 | 17 | Added RPROG |

Note: Change 1 = Dec. 1998 changes from July 1998 "Preliminary."
Change 2 = May 1999 B changes from Dec. 1998.

bq2013H

Ordering Information

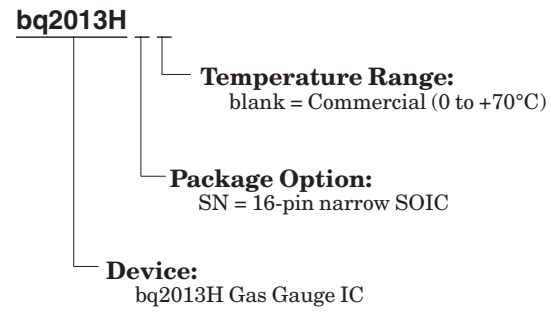

PACKAGING INFORMATION

| Orderable Device | Status ⁽¹⁾ | Package Type | Package Drawing | Pins | Package Qty | Eco Plan ⁽²⁾ | Lead/Ball Finish | MSL Peak Temp ⁽³⁾ |
|--------------------|-----------------------|--------------|-----------------|------|-------------|-------------------------|------------------|------------------------------|
| BQ2013HSN-A514 | ACTIVE | SOIC | D | 16 | 40 | Green (RoHS & no Sb/Br) | CU NIPDAU | Level-2-260C-1 YEAR |
| BQ2013HSN-A514G4 | ACTIVE | SOIC | D | 16 | 40 | Green (RoHS & no Sb/Br) | CU NIPDAU | Level-2-260C-1 YEAR |
| BQ2013HSN-A514TR | ACTIVE | SOIC | D | 16 | 2500 | Green (RoHS & no Sb/Br) | CU NIPDAU | Level-2-260C-1 YEAR |
| BQ2013HSN-A514TRG4 | ACTIVE | SOIC | D | 16 | 2500 | Green (RoHS & no Sb/Br) | CU NIPDAU | Level-2-260C-1 YEAR |

⁽¹⁾ The marketing status values are defined as follows:

ACTIVE: Product device recommended for new designs.

LIFEBUY: TI has announced that the device will be discontinued, and a lifetime-buy period is in effect.

NRND: Not recommended for new designs. Device is in production to support existing customers, but TI does not recommend using this part in a new design.

PREVIEW: Device has been announced but is not in production. Samples may or may not be available.

OBSOLETE: TI has discontinued the production of the device.

⁽²⁾ Eco Plan - The planned eco-friendly classification: Pb-Free (RoHS), Pb-Free (RoHS Exempt), or Green (RoHS & no Sb/Br) - please check <http://www.ti.com/productcontent> for the latest availability information and additional product content details.

TBD: The Pb-Free/Green conversion plan has not been defined.

Pb-Free (RoHS): TI's terms "Lead-Free" or "Pb-Free" mean semiconductor products that are compatible with the current RoHS requirements for all 6 substances, including the requirement that lead not exceed 0.1% by weight in homogeneous materials. Where designed to be soldered at high temperatures, TI Pb-Free products are suitable for use in specified lead-free processes.

Pb-Free (RoHS Exempt): This component has a RoHS exemption for either 1) lead-based flip-chip solder bumps used between the die and package, or 2) lead-based die adhesive used between the die and leadframe. The component is otherwise considered Pb-Free (RoHS compatible) as defined above.

Green (RoHS & no Sb/Br): TI defines "Green" to mean Pb-Free (RoHS compatible), and free of Bromine (Br) and Antimony (Sb) based flame retardants (Br or Sb do not exceed 0.1% by weight in homogeneous material)

⁽³⁾ MSL, Peak Temp. -- The Moisture Sensitivity Level rating according to the JEDEC industry standard classifications, and peak solder temperature.

Important Information and Disclaimer: The information provided on this page represents TI's knowledge and belief as of the date that it is provided. TI bases its knowledge and belief on information provided by third parties, and makes no representation or warranty as to the accuracy of such information. Efforts are underway to better integrate information from third parties. TI has taken and continues to take reasonable steps to provide representative and accurate information but may not have conducted destructive testing or chemical analysis on incoming materials and chemicals. TI and TI suppliers consider certain information to be proprietary, and thus CAS numbers and other limited information may not be available for release.

In no event shall TI's liability arising out of such information exceed the total purchase price of the TI part(s) at issue in this document sold by TI to Customer on an annual basis.

D (R-PDSO-G16)

PLASTIC SMALL-OUTLINE PACKAGE



4040047-4/F 07/2004

- NOTES:
- All linear dimensions are in inches (millimeters).
 - This drawing is subject to change without notice.
 - Body dimensions do not include mold flash or protrusion not to exceed 0.006 (0,15).
 - Falls within JEDEC MS-012 variation AC.